



RUNFLEX GEAR COUPLINGS are designed for applications where high torque and balance is required. It consists of Forged sleeve with internal gear teeth and two identical Hubs with external gear teeth. The teeth of Hub and Sleeve are continuously in contact with each other transmitting torque from one end to another end and are designed to accommodate maximum angular, parallel and axial misalignment. The teeth are crowned for maximum load carrying capacity with minimum size.

RUNFLEX GEAR COUPLINGS are widely used in Cement plants, Conveyors and Elevators, Metal Rolling Mills, Paper Machinery, Cranes, Dredgers, Rubber and Plastic Industries, Compressors, Fans and Blowers, Screens and other general industries.

FEATURES :

- ▶ High power to weight ratio.
- ▶ Crown gear teeth for longer life.
- ▶ Less backlash error.
- ▶ High torque capacity.
- ▶ Compact design.
- ▶ Larger bore capacities.
- ▶ Reliable and Maintenance friendly.
- ▶ Fully interchangeable with other couplings.

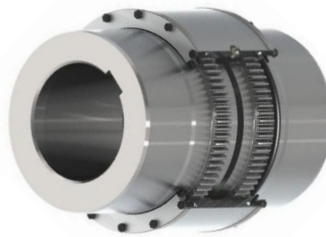

RFG SERIES
(FULL GEAR)



RHG SERIES
(HALF GEAR)

SELECTION PROCEDURE:



SERVICE FACTOR TABLE :

DRIVEN MACHINE	DRIVER MACHINE		
	ELECTRIC MOTOR / STEAM TURBINE	STEAM ENGINE / WATER TURBINE	GAS ENGINE / OIL ENGINE
CONSTANT TORQUE FLUCTUATIONS Centrifugal pumps, Compressors, Light fans, Alternators, Conveyors, etc.	1.0	1.5	3.0
LIGHT TORQUE FLUCTUATIONS Screw pumps & compressors, Rotary compressors & dryers, Textiles machinery, Draught fans, Paper mill winder, marine propellers, etc.	1.5	2.0	3.0
MEDIUM TORQUE FLUCTUATIONS Reciprocating pumps, Bucket elevators, Crane & winders, Paper mills, Positive displacement pumps, etc.	2.0	2.5	4.0
HIGH TORQUE FLUCTUATIONS Reciprocating conveyors, High velocity mixtures, Rubber machinery, Crusher ball mills, Cooling towers, etc.	3.0	3.5	5.0

RUNFLEX FULL GEAR COUPLING (RFG SERIES)

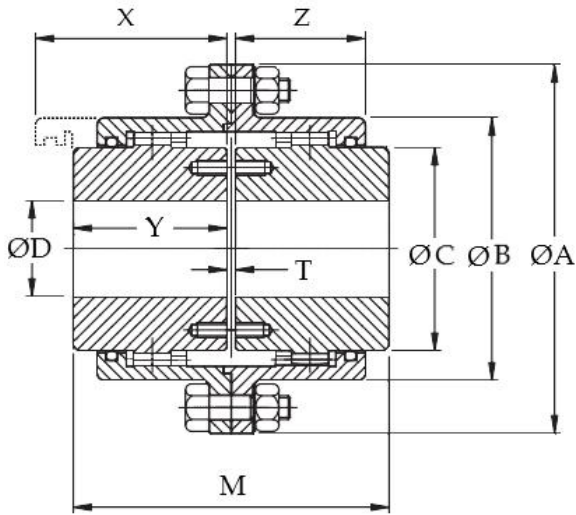

SIZE: RFG - 100 TO RFG - 110

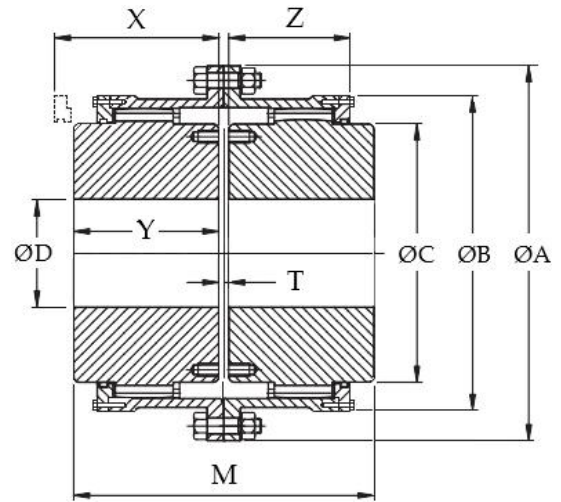

SIZE: RFG - 111 TO RFG - 119

SIZE	RATING G kW@ 100 RPM	TORQUE Nm	MAX SPEED (RPM)	BORE ØD		ØA	ØB	ØC	Y	Z	T	M	X	WT in KG	M.I IN Kgm2
				P.B	MAX										
RFG - 100	7	668	7500	10	35	120	75	50	45	40	3	93	55	4.2	0.0065
RFG - 101	13	1242	6100	15	50	170	110	65	55	49	5	115	65	11	0.03
RFG - 102	30	2865	5200	20	60	185	125	85	70	62	5	145	80	15	0.05
RFG - 103	54	5157	4200	30	75	220	150	105	85	78	5	175	105	25	0.12
RFG - 104	105	10028	3400	40	90	250	175	130	105	96	5	215	125	39	0.22
RFG - 105	155	14803	3000	45	110	290	200	155	110	106	10	230	140	59	0.45
RFG - 106	240	22920	2600	50	125	320	230	175	125	117	10	260	155	85	0.75
RFG - 107	415	39633	2000	60	140	350	260	205	140	134	10	290	175	104	1.22
RFG - 108	530	50615	1850	70	160	380	290	230	155	147	10	320	190	140	2.1
RFG - 109	670	63985	1600	80	180	430	330	250	165	156	10	340	205	210	3.5
RFG - 110	970	92635	1300	100	220	490	390	310	180	171	10	370	220	285	5.7
RFG - 111	1300	124150	1200	110	260	545	445	350	200	192	10	410	240	550	14.9
RFG - 112	1730	165215	1100	150	300	590	490	400	240	231	10	490	280	720	23.5
RFG - 113	2915	278383	950	200	330	680	555	440	260	242	15	535	310	980	42
RFG - 114	4025	384388	850	220	370	730	610	500	280	266	15	575	330	1225	65
RFG - 115	4850	463175	700	250	410	780	660	540	320	305	15	655	370	1600	98
RFG - 116	7100	678050	650	300	455	900	755	625	350	335	20	720	423	2260	185
RFG - 117	10000	955000	600	325	520	1000	855	720	400	386	20	820	490	3250	340
RFG - 118	13500	1289200	550	350	610	1100	950	810	450	430	20	920	533	4700	602
RFG - 119	17500	1671200	450	375	710	1250	1050	910	485	446	30	1000	558	6300	960

NOTE:

1. ALL DIMENSIONS ARE IN MM.
2. WEIGHTS AND M.I ARE SPECIFIED CONSIDERING P.B.
3. MAX. TORQUE IS 3 TIMES THE NORMAL TORQUE.
4. COUPLING WITH SPACER WILL BE AVAILABLE ON REQUEST
5. TOLERANCE ON FINISH BORE & KEYWAY WILL BE H7 & JS9 RESPECTIVELY AS PER BS 4235 : PART 1 : 1972

MATERIAL SPECIFICATION:

HUB	EN9 FORGED STEEL
SLEEVE	EN9 (SIZE RFG - 100 TO RFG - 106)
SLEEVE	CAST STEEL (SIZE RFG - 107 TO RFG - 119)
'O' RING	SYNTHETIC RUBBER
GASKET	BETA FLEX
HEX BOLT	HIGH TENSILE

CONSTRUCTION

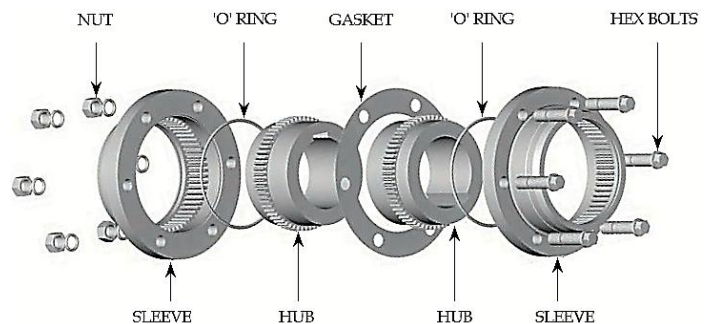

RUNFLEX HALF GEAR COUPLING (RFG SERIES)

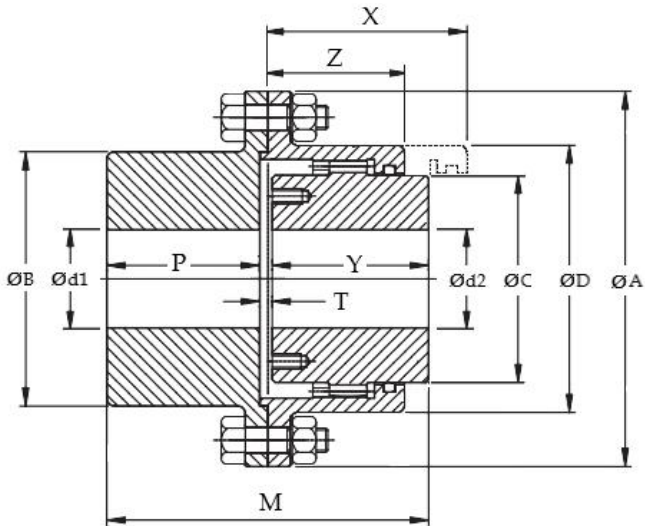

SIZE: RHG - 100 TO RFG - 104

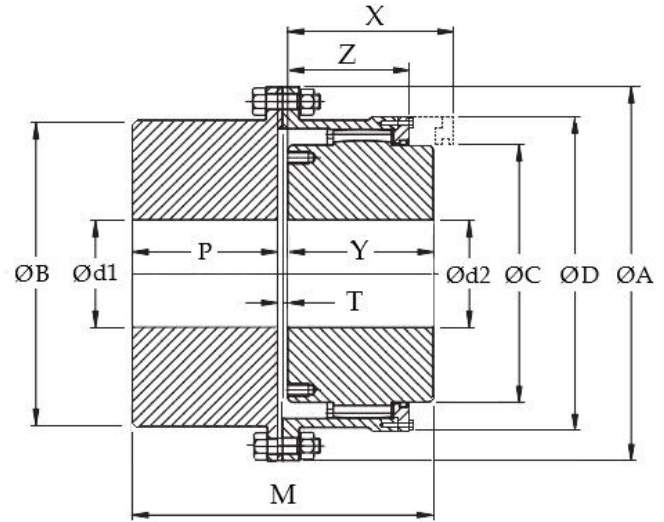

SIZE: RHG - 105 TO RHG - 110

SIZE	RATING @ 100 RPM	TORQUE Nm	MAX SPEED (RPM)	BORE			ØA	ØB	ØC	ØD	X	Y	Z	T	P	M	WT in KG	M.I IN Kg ^m 2
				P. B	Ød1	Ød2												
RHG - 100	7	668	7500	10	45	35	120	65	50	75	55	45	40	3	45	93	4.5	0.0070
RHG - 101	13	1242	6100	15	60	50	170	85	65	110	65	55	49	5	55	115	12	0.035
RHG - 102	30	2865	5200	20	75	60	185	110	85	125	80	70	62	5	70	145	16	0.06
RHG - 103	54	5157	4200	30	90	75	220	130	105	150	105	85	78	5	85	175	28	0.14
RHG - 104	105	10028	3400	40	110	90	250	160	130	175	125	105	96	5	105	215	41	0.25
RHG - 105	155	14803	3000	45	130	110	290	185	155	200	140	110	106	10	110	230	62	0.49
RHG - 106	240	22920	2600	50	150	125	320	215	175	230	155	125	117	10	125	260	87	0.80
RHG - 107	415	39633	2000	60	170	140	350	240	205	260	175	140	134	10	140	290	108	1.28
RHG - 108	530	50615	1850	70	200	160	380	285	230	290	190	155	147	10	155	320	143	2.4
RHG - 109	670	63985	1600	80	220	180	430	315	250	330	205	165	156	10	165	340	212	3.7
RHG - 110	970	92635	1300	100	260	220	490	370	310	390	220	180	171	10	180	370	300	6

NOTE:

1. ALL DIMENSIONS ARE IN MM.
2. WEIGHTS AND M.I ARE SPECIFIED CONSIDERING P.B.
3. MAX. TORQUE IS 3 TIMES THE NORMAL TORQUE.
4. COUPLING WITH SPACER WILL BE AVAILABLE ON REQUEST
5. TOLERANCE ON FINISH BORE & KEYWAY WILL BE H7 & JS9 RESPECTIVELY AS PER BS 4235 : PART 1 : 1972

MATERIAL SPECIFICATION:

HUB	EN9 FORGED STEEL
SLEEVE	EN9 (SIZE RHG - 100 TO RHG - 106)
SLEEVE	CAST STEEL (SIZE RHG - 107 TO RHG - 110)
'O' RING	SYNTHETIC RUBBER
GASKET	BETA FLEX
HEX BOLT	HIGH TENSILE

CONSTRUCTION

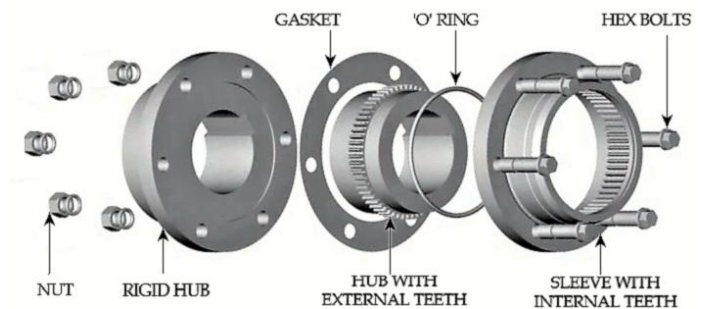

RUNFLEX CUSTOM MADE COUPLINGS

RUNFLEX CUSTOM MADE GEAR COUPLINGS are designed & developed to meet specific requirements given by user for most effective power transmission with specific feature. Following are some special or custom made designs.

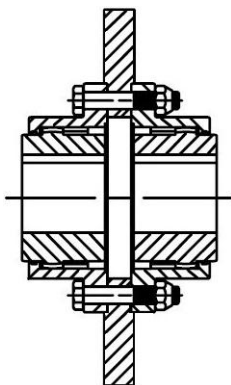

BREAK DISC TYPE
GEAR COUPLING

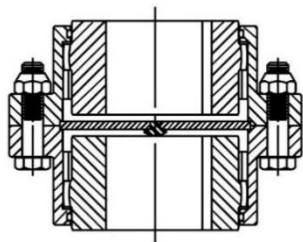

VERTICAL ARRANGEMENT
GEAR COUPLING

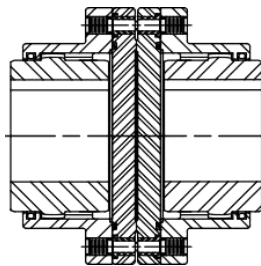

SHEAR PIN TYPE
GEAR COUPLING

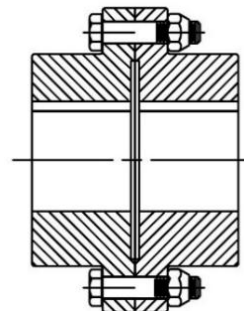

RIGID COUPLING

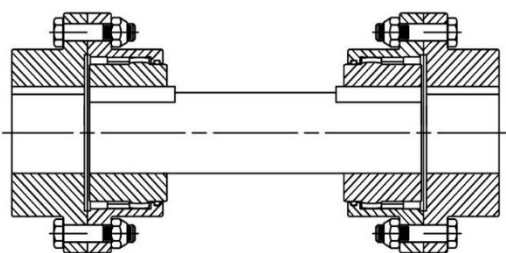

FLOATING SHAFT
GEAR COUPLING

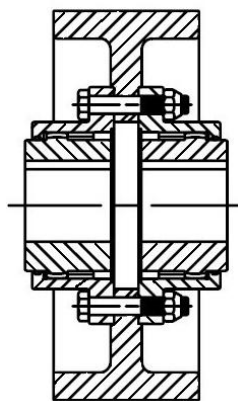

DRUM TYPE
GEAR COUPLING

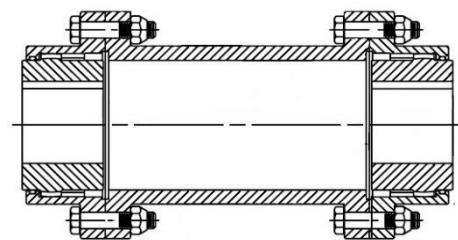

SPACER TYPE
GEAR COUPLING

SEND US YOUR REQUIREMENTS IN DETAIL TO GET THE MOST EFFECTIVELY DESIGNED COUPLING AS PER YOUR REQUIREMENT

For more information about other products, please visit our website.



RUNFLEX
TRANSMISSIONS PVT. LTD.

AUTHORISED DEALER

OFFICE : 25/7 DEDGE INDUSTRIES, NANDED PHATA, SINHAGAD ROAD, PUNE - 411041

CONTACT : 9422089962 / 9545565527

EMAIL : runflex.transmissions@gmail.com

Website : www.runflextransmissions.com